

(12) **UK Patent Application** (19) **GB** (11) **2 304 051** (13) **A**

(43) Date of A Publication **12.03.1997**

<p>(21) Application No <b>9516354.9</b></p> <p>(22) Date of Filing <b>09.08.1995</b></p>	<p>(51) INT CL<sup>6</sup> <b>A61F 2/38</b></p>
<p>(71) Applicant(s) <b>Corin Medical Limited</b>  (Incorporated in the United Kingdom)  <b>The Corinium Centre, Chesterton Lane, CIRENCESTER, Gloucestershire, GL7 1YJ, United Kingdom</b></p> <p>(72) Inventor(s) <b>George John James Cremore Antony Massarella</b></p> <p>(74) Agent and/or Address for Service <b>Marks &amp; Clerk 57-60 Lincoln's Inn Fields, LONDON, WC2A 3LS, United Kingdom</b></p>	<p>(52) UK CL (Edition O ) <b>A5R RAK</b></p> <p>(56) Documents Cited <b>GB 2252500 A          EP 0186471 A2</b></p> <p>(58) Field of Search UK CL (Edition N ) <b>A5R RAJ RAK</b> INT CL<sup>6</sup> <b>A61F 2/38</b> <b>ONLINE:WPI</b></p>

(54) **A Knee Prosthesis Having Interchangeable Meniscal Components**

(57) A knee prosthesis comprises a tibial component 20, a femoral component 10 and one of a plurality of meniscal components 30 each of the plurality of meniscal components (30,30a,30b,30c) being configured to cooperate with the tibial and femoral components 20,10 in a different manner and at least one of the meniscal components (30a) being configured to cooperate with the tibial component 20 such that relative movement therebetween is prevented. Once the tibial and femoral components are in place the appropriate meniscal component may be selected to suit the individual patient's needs and also replaced once it becomes worn.

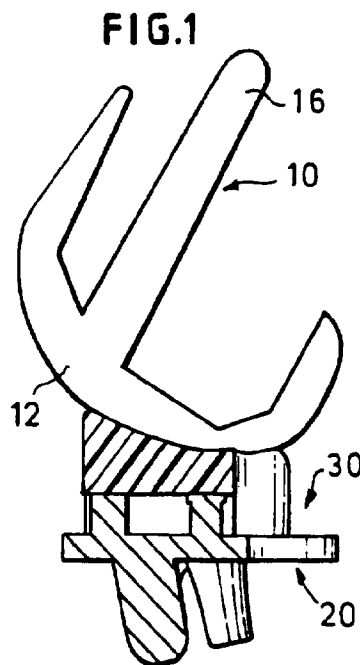

**GB 2 304 051 A**

FIG.1

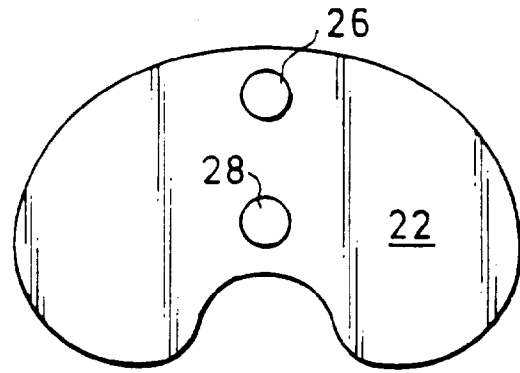
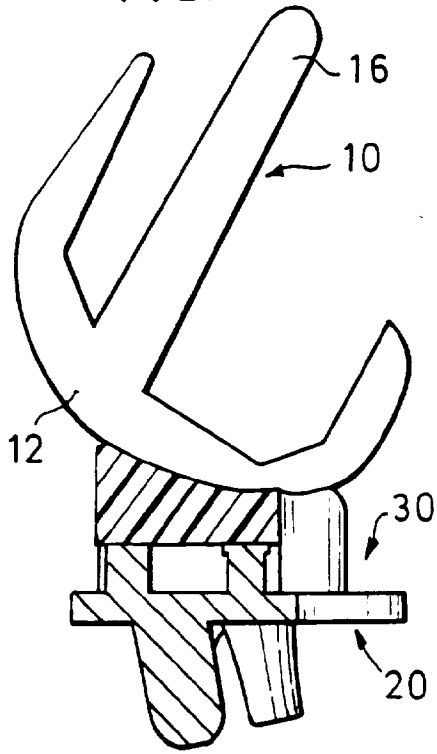

FIG.2a

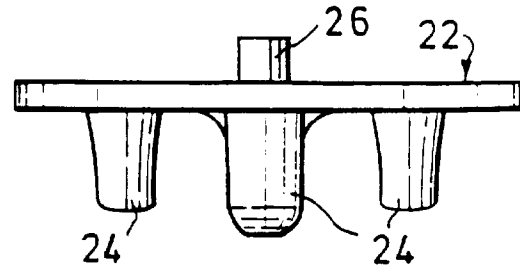

FIG.2b

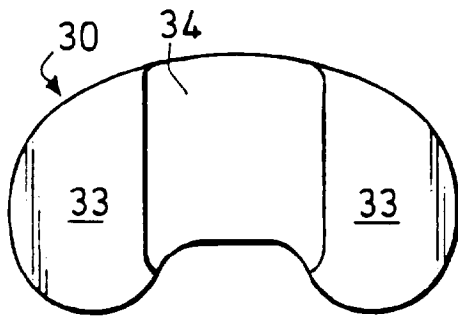

FIG.3a

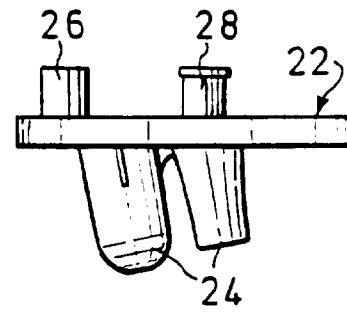

FIG.2c

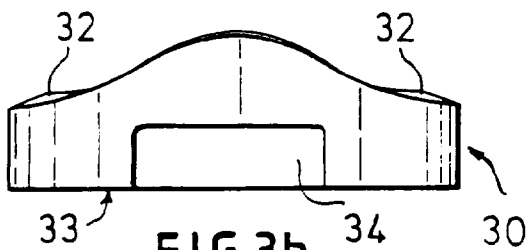

FIG.3b

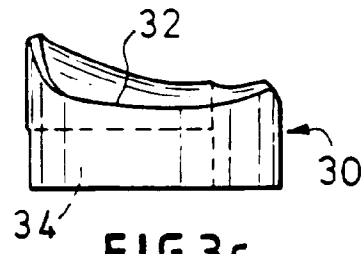

FIG.3c

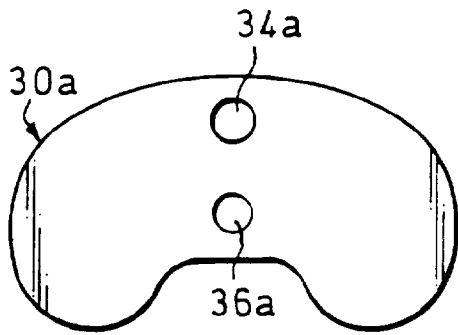

FIG. 4a

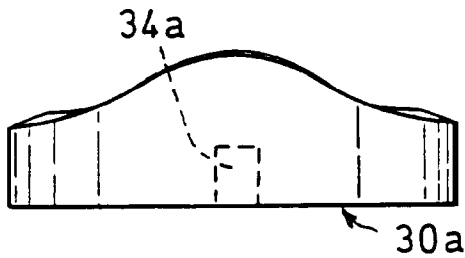

FIG. 4b

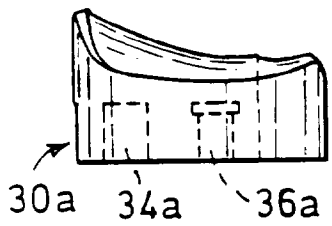

FIG. 4c

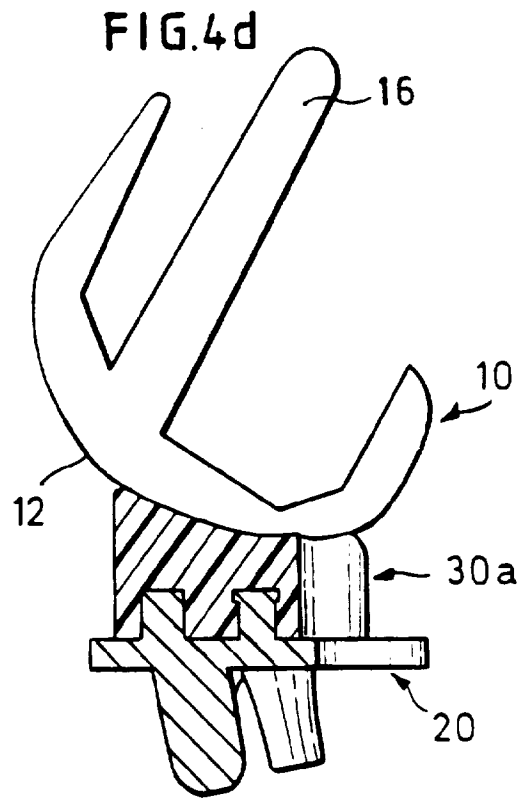

FIG. 4d

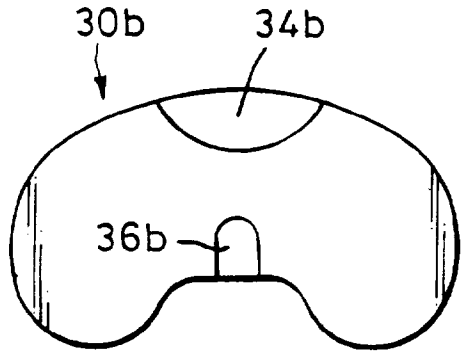

FIG. 5a

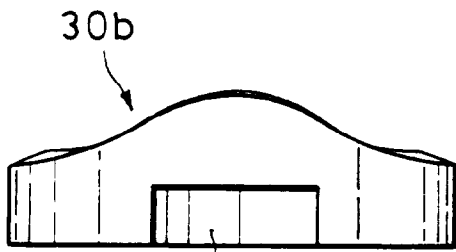

FIG. 5b

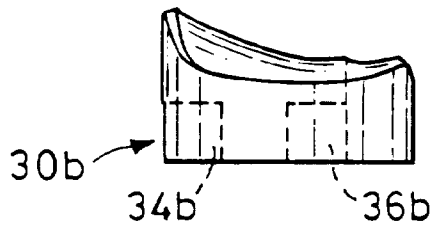

FIG. 5c

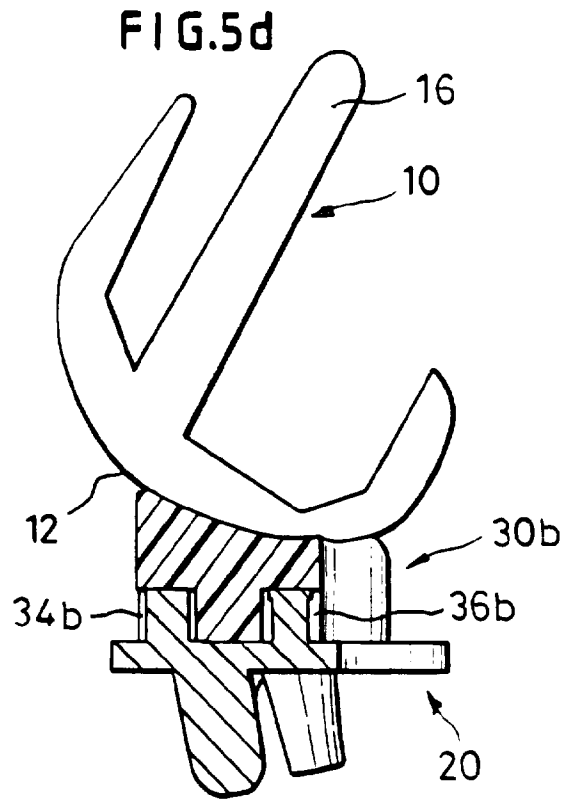

FIG. 5d

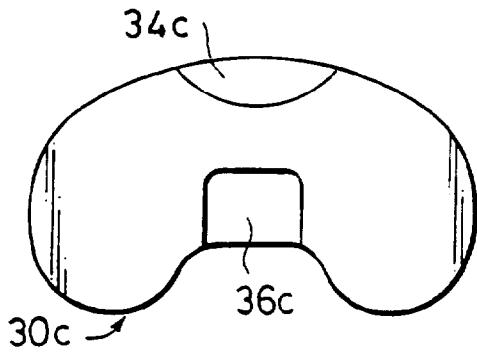

FIG. 6a

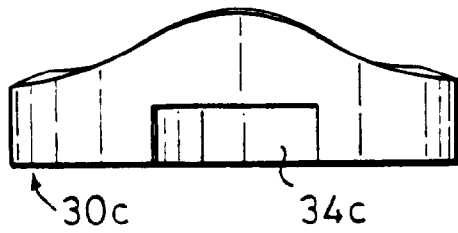

FIG. 6b

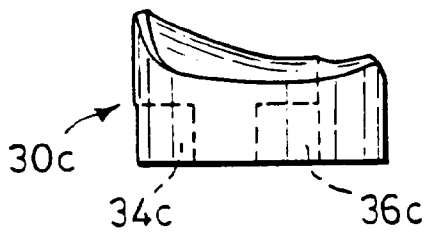

FIG. 6c

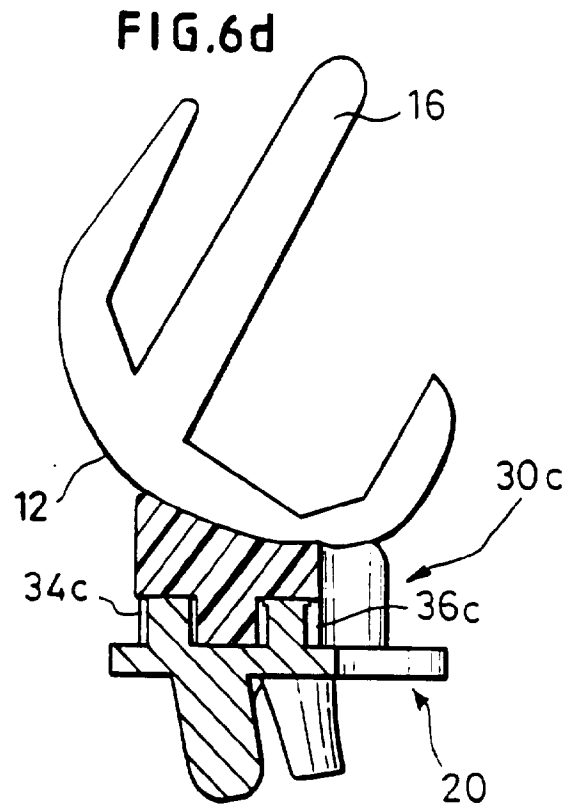

FIG. 6d

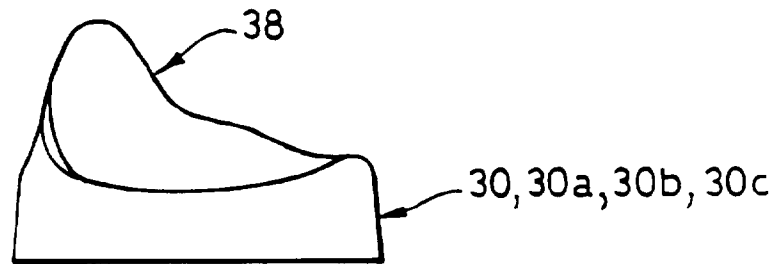

FIG. 7

**2304051**A KNEE PROSTHESIS

The invention relates to a knee prosthesis.

Knee prostheses comprising a femoral component, a tibial component and a meniscal component are well known. There are many different manners of operation of such knee prostheses and the surgeon selects the prosthesis he requires for a particular patient with regard to whether that patient will require a fixed meniscal component, limited anterior-posterior movement, or other known available manners of operation. Once the requirements of the patient have been determined, an appropriate prosthesis can be selected for implantation.

The selection of the prosthesis depends, naturally, on the surgeon assessing the patient's requirements correctly. This can be difficult and the surgeon may, on occasion, be forced to make assumptions which eventually turn out to be incorrect. He may also occasionally make a mistake. However, once a prosthesis has been implanted, it is extremely disruptive and inconvenient to remove it and replace it with a more appropriate prosthesis. For example, a surgeon may implant a prosthesis having no relative movement between the tibial and meniscal components only to find at a later date that the patient does in fact require a

prosthesis which allows limited relative movement. In order to rectify the situation, the prosthesis may have to be removed completely and replaced.

At present, the only prostheses available which are designed to allow the manner of operation to be changed relate to the introduction or removal of a posterior stabilisation facility by replacing both the femoral and meniscal components. In other respects, each prosthesis is designed to function in one particular manner and no interchangeability is catered for. It is an object of the present invention to provide a knee prosthesis whose manner of operation, in respects other than posterior stabilisation, can be changed purely by the replacement of the meniscal component. The femoral and tibial components do not then require to be replaced.

The invention provides a knee prosthesis as set out in claim 1. The invention also provides a combination as set out in claim 14 and a set of meniscal components as claimed in claim 15. Advantageous features of the invention are set out in the subsidiary claims.

The invention provides a hitherto unattainable degree of freedom and flexibility in respect of knee prostheses. Once the tibial and femoral components are in place, the manner of operation of the knee can be varied to suit the patient's needs by appropriate selection of the meniscal component. For example, one selectable meniscal component may be configured so as to

be able to glide in a substantially unrestrained manner across the upper surface of the tibial component. Other meniscal components may be configured so as to be able to move in a limited manner in any one of the anterior-posterior, medial-lateral and rotational directions or in any combinations of these. Another meniscal component may be configured so as to engage with the tibial component such that no movement relative thereto is permitted. Thereby, the surgeon can select the manner of operation of the knee prosthesis from a wide variety of possibilities without needing to select, order, obtain and check a complete knee prosthesis.

A further advantage of the prosthesis of the invention is that, should the implanted knee prove inadequate or defective in its manner of operation, it is a relatively simple matter to replace the existing meniscal component with an alternative which may perform better. For example, a surgeon may implant a prosthesis believing that medial-lateral movement between the tibial and meniscal components is not necessary but may subsequently find that such movement is desirable after all. Normally, converting the prosthesis to one having the desired ability to achieve medial-lateral movement would involve replacing the tibial component as well as the meniscal component at least but, with the prosthesis of the invention, the conversion can be achieved merely by changing the meniscal component.



An embodiment of the invention will now be described with reference to the accompanying drawings, wherein:

Figure 1 is a side view, partly in section, of a knee prosthesis according to the invention;

Figures 2a, 2b and 2c are plan, front and side views respectively of the tibial component shown in Figure 1;

Figures 3a, 3b and 3c are underneath, front and side views respectively of the meniscal component shown in Figure 1;

Figures 4a, 4b and 4c are underneath, front and side views respectively of a first alternative meniscal component and Figure 4d is a side view, partly in section, of a knee prosthesis incorporating the first alternative meniscal component;

Figures 5a, 5b and 5c are underneath, front and side views respectively of a second alternative meniscal component and Figure 5d is a side view, partly in section, of a knee prosthesis incorporating the second alternative meniscal component; and

Figures 6a, 6b and 6c are underneath, front and side views respectively of a third alternative meniscal component and Figure 6d is a side view, partly in section, of a knee prosthesis incorporating the third alternative meniscal component.

The knee prosthesis of the invention essentially consists of a femoral component 10, a tibial component 20 and a meniscal component 30, the meniscal component

30 being one of a predetermined set of meniscal components, each of which is configured so as to cooperate with the tibial and femoral components 10, 20 in a different manner. Figure 1 illustrates the manner in which the three components are assembled in use. Essentially, the tibial component 20 supports the meniscal component 30 which, in turn, supports the femoral component 10.

The femoral component 10 is of standard design and has two condylar surfaces 12. The femoral component 10 also comprises a fixing stem 16 and may also include further pegs for fixing purposes if required. All of the features of the femoral component 10 are individually known and will not be described any further here.

The tibial component 20 is shown in detail in Figures 2a, 2b and 2c. Essentially, the tibial component 20 comprises a planar surface or plateau 22 from which depend fixing pegs and stems 24 of standard design. The exact design and configuration of the fixing pegs and stems 24 can be varied to suit individual needs as desired.

On the upper surface of the plateau 22 are arranged two bollards or pegs 26, 28. The anterior peg 26 is larger in diameter than the posterior peg 28. Both pegs 26, 28 lie on the longitudinal axis of the upper surface 22 of the tibial component 20.

The anterior peg 26 is substantially cylindrical in shape. However, the posterior peg 28 is slightly under-cut (see Figure 2c) for reasons which will be explained later on.

The meniscal component 30 illustrated in Figure 1 is shown in more detail in Figures 3a, 3b and 3c. As can be seen from the drawings, the meniscal component 30 has two condylar supporting surfaces 32 which are shaped so as to adequately support the condylar surfaces 12 of the femoral component 10. The lower surface 33 of the meniscal component 30 is substantially planar but also incorporates a central recess 34 which extends from the anterior edge of the meniscal component 30 to the posterior edge thereof.

When the meniscal component 30 is located between the femoral and tibial components, the upstanding pegs 26, 28 of the tibial component 20 extend into the recess 34 of the meniscal component 30. However, the size of the recess 34 is such that the pegs 26, 28 do not approach or abut the side walls of the recess 34 and therefore, during normal operation of the knee prosthesis, the lower surface 33 of the meniscal component 30 is able to glide across the upper surface 22 of the tibial component in a substantially unrestrained manner. Unrestrained relative movement between the tibial and meniscal components 20, 30 is therefore possible during flexion of the knee.

An alternative meniscal component 30a is illustrated in Figures 4a, 4b and 4c. The underside of the meniscal component 30a, as shown in Figure 4a, has two cylindrical recesses 34a, 36a arranged along the axis of symmetry of the meniscal component 30a. The anterior recess 34a is substantially the same diameter and depth as the anterior peg 26 arranged on the tibial component 20. The posterior recess 36a is also substantially the same diameter and depth as the posterior peg 28 arranged on the tibial component 20. There is a small step arranged in the cylindrical wall of the posterior recess 36a which cooperates with the slight undercut in the posterior peg 28 so as to allow the meniscal component 30a to be brought into snap-fitting engagement with the tibial component 20.

Figure 4d illustrates the meniscal component 30a in combination with the tibial component 20 and femoral component 10 illustrated in Figure 1. It will be appreciated that, when the meniscal component 30a is brought into interengagement with the tibial component 20, no relative movement between these components will be allowed. The advantage of having the meniscal component 30a manufactured separately from the tibial component 20 and subsequently releasably attached thereto even though no relative movement is permitted is that the meniscal component 30a can be replaced when it becomes worn. Also, the highly polished upper surface

22 of the tibial component 20 reduces any fretting and wear at the interface between the tibial component 20 and the meniscal component 30a.

A further alternative meniscal component 30b is illustrated in Figures 5a, 5b and 5c. The underside of the meniscal component 30b has, once again, two recesses 34b, 36b. This time, the anterior recess 34b is part-cylindrical in plan view and opens onto the side wall of the meniscal component 30b. The posterior recess 36b also opens onto the posterior wall of the meniscal component 30b but has a diameter substantially identical to the diameter of the posterior peg 28 on the tibial component 20.

When the meniscal component 30b is brought into interengagement with the tibial component 20 as illustrated in Figure 5d, the pegs 26, 28 are received into the recesses 34b, 36b. The shape and spacing of the pegs 26, 28 and recesses 34b, 36b is such that a limited amount of anterior-posterior movement is permitted. Also, the anterior peg 26 can move within the anterior recess 34b so as to allow a limited amount of rotational movement of the meniscal component 30b with respect to the tibial component 20 about an axis passing through the posterior peg 28.

Another alternative meniscal component 30c is illustrated in Figures 6a, 6b and 6c. The meniscal component 30c is similar to the meniscal component 30b

illustrated in Figures 5a, 5b and 5c. The anterior recess 34c is identical to the anterior recess 34b of the meniscal component 30b. However, the posterior recess 36c of the meniscal component 30c is wider in the medial-lateral direction than the posterior recess 36b. When the meniscal component 30c is brought into interengagement with the tibial component 20, the meniscal component 30c is permitted to move in the anterior-posterior, medial-lateral and rotational directions to a limited extent in each case.

Furthermore, even when the meniscal component 30c is at the extremes of medial-lateral movement, some limited rotation about an axis passing through the posterior peg 28 can still take place. This is due to the fact that the posterior recess 36c is not as wide in the medial-lateral direction as the anterior recess 34c.

The meniscal components illustrated in Figures 3a-3c, 4a-4c, 5a-5c and 6a-6c form a plurality or set from which any one can be taken to form a knee prosthesis in combination with the femoral and tibial components 10, 20 shown in Figure 1. It will be appreciated that four alternative manners of operation can be selected from by choosing the appropriate meniscal component 30, 30a, 30b, 30c, one of which provides a knee prosthesis in which no relative movement is allowed between the meniscal and tibial components 30a, 20.

If desired, the meniscal components 30, 30a, 30b, 30c can also be provided with an intercondylar spine 38 illustrated in Figure 7 so as to provide posterior stabilisation. The femoral component 10 is then also provided with an intercondylar notch (not shown) such that, when the knee is flexed, the cooperation of the spine 38 and the notch will act so as to prevent the femoral component 10 from slipping out of contact with the meniscal component 30, 30a, 30b, 30c in the anterior direction.

It will be appreciated, therefore, that the invention essentially comprises a standard tibial component, a standard femoral component and any one of a plurality of meniscal components designed to cooperate with the standard tibial and femoral components. In the embodiment illustrated above, four alternative meniscal components are provided, namely the four meniscal components illustrated in Figures 3, 4, 5 and 6. An alternative embodiment comprises the same tibial component, a femoral component with an added intercondylar notch and the same meniscal components but with an intercondylar spine added. The invention also covers a complete "kit of parts" consisting of the tibial component, the femoral component and a complete set of alternative meniscal components. The invention also encompasses a set of meniscal components, each designed or adapted to cooperate with a single femoral

component and a single meniscal component. In each case, one of the meniscal components is configured to cooperate with the or a tibial component such that relative movement therebetween is prevented.

It is advantageous if the meniscal component is made from ultra-high molecular weight polyethylene and if the tibial and femoral components are made of a chrome-cobalt alloy. However, other implant-grade materials can alternatively be used. The nature, shaping, spacing and number of fixing pegs and stems provided on the femoral and tibial components can be varied to suit any particular requirements and, if required, suitable surface textures and/or coatings for promoting bone ingrowth can be provided.



CLAIMS

1. A knee prosthesis comprising, in combination, a tibial component, a femoral component and one of a plurality of meniscal components, each of the plurality of meniscal components being configured to cooperate with the tibial and femoral components in a different manner, wherein at least one of the meniscal components is configured to cooperate with the tibial component such that relative movement therebetween is prevented.
2. A knee prosthesis as claimed in claim 1, wherein the meniscal component is configured to glide across an upper surface of the tibial component in a substantially unrestrained manner.
3. A knee prosthesis as claimed in claim 1, wherein interengaging means are provided between the meniscal and tibial components such that limited relative movement between the tibial and meniscal components is permitted.
4. A knee prosthesis as claimed in claim 3, wherein anterior-posterior and rotational movement is permitted between the meniscal and tibial components.

5. A knee prosthesis as claimed in claim 3 or 4, wherein medial-lateral movement is permitted between the meniscal and tibial components.
6. A knee prosthesis as claimed in claim 1, wherein interengaging means are provided between the meniscal and tibial components such that no relative movement between the said components is permitted.
7. A knee prosthesis as claimed in any one of claims 3 to 6, wherein the interengaging means comprise at least one cooperating peg and recess.
8. A knee prosthesis as claimed in claim 7, wherein two pegs and recesses are provided.
9. A knee prosthesis as claimed in claim 7 or 8, wherein the or each peg is located on an upper surface of the tibial component and the or each recess is located in a lower surface of the meniscal component.
10. A knee prosthesis as claimed in any one of claims 7 to 9, wherein at least one peg is locatable in the or each corresponding recess in a snap-fit manner.
11. A knee prosthesis as claimed in any one of the preceding claims, wherein the tibial and femoral

components are made from a cobalt-chrome alloy.

12. A knee prosthesis as claimed in any one of the preceding claims, wherein the meniscal component is made from ultra-high molecular weight polyethylene.

13. A knee prosthesis substantially as hereinbefore described with reference to the accompanying drawings.

14. The combination of a tibial component, a femoral component and a plurality of meniscal components, the tibial and femoral components and any one of the meniscal components serving to make up a knee prosthesis, wherein each meniscal component is configured to cooperate with the tibial and femoral components in a different manner to allow alternative modes of operation of the knee prosthesis and wherein at least one of the meniscal components is configured to cooperate with the tibial component such that relative movement therebetween is prevented.

15. A set of meniscal components, each configured so as to cooperate with a single tibial component and a single femoral component to provide a knee prosthesis, each meniscal component being adapted so as to allow an alternative mode of operation of the knee prosthesis, wherein at least one of the meniscal components is

configured to cooperate with the tibial component such that relative movement therebetween is prevented.

16. A combination or set as claimed in claim 14 or 15, wherein one of the meniscal components is configured to glide across an upper surface of the tibial component in a substantially unrestrained manner.

17. A combination or set as claimed in any one of claims 14 to 16, wherein one of the meniscal components has at least one recess for receiving at least one upstanding peg on the upper surface of the tibial component such that, in use, limited anterior-posterior and rotational movement is permitted between the said meniscal component and the tibial component.

18. A combination or set as claimed in any one of claims 14 to 17, wherein one of the meniscal components has at least one recess for receiving at least one upstanding peg on the upper surface of the tibial component such that, in use, limited anterior-posterior, medial-lateral and rotational movement is permitted between the said meniscal component and the tibial component.

19. A combination of a tibial component, a femoral component and a plurality of meniscal components substantially as hereinbefore described with reference

to either of the embodiments illustrated in the accompanying drawings.

20. A set of meniscal components substantially as hereinbefore described with reference to Figures 3a-3c, 4a-4c, 5a-5c and 6a-6c of the accompanying drawings.

21. A set of meniscal components substantially as hereinbefore described with reference to Figures 3a-3c, 4a-4c, 5a-5c 6a-6c and 7 of the accompanying drawings.

**Amendments to the claims have been filed as follows**

1. A knee prosthesis comprising, in combination, a tibial component, a femoral component and one of a plurality of meniscal components, each of the meniscal components being configured to cooperate with the tibial and femoral components in a different manner, and interengaging means being provided between the meniscal and tibial components, wherein the interengaging means comprise at least two pegs projecting upwardly from an upper surface of the tibial component and at least one recess in a lower surface of the meniscal component for receiving the pegs, and wherein the pegs are fixedly connected to or formed integrally with the tibial component.
2. A knee prosthesis as claimed in claim 1, wherein the recess in at least one of the meniscal components is configured to allow gliding of the or each meniscal component across the upper surface of the tibial component in a substantially unrestrained manner.
3. A knee prosthesis as claimed in claim 1 or 2, wherein at least one of the meniscal components is configured to cooperate with the tibial component such that relative movement therebetween is prevented.
4. A knee prosthesis as claimed in any one of claims 1 to 3, wherein at least one of the meniscal components is configured to cooperate with the tibial component such that limited relative movement therebetween is allowed.
5. A knee prosthesis as claimed in claim 4, wherein limited anterior-posterior and rotational movement between the said meniscal and tibial components is allowed.
6. A knee prosthesis as claimed in claim 4 or 5, wherein limited medial-lateral movement between the said meniscal and tibial components is allowed.

7. A knee prosthesis as claimed in any one of the preceding claims, wherein at least one of the pegs is locatable in at least one recess in a snap-fit manner.
8. A knee prosthesis as claimed in any one of the preceding claims, wherein the tibial and femoral components are made from a cobalt-chrome alloy.
9. A knee prosthesis as claimed in any one of the preceding claims, wherein the meniscal component is made from ultra-high molecular weight polyethylene.
10. A knee prosthesis substantially as hereinbefore described with reference to the accompanying drawings.
11. The combination of a tibial component, a femoral component and a plurality of meniscal components, the tibial and femoral components and any one of the meniscal components serving to make up a knee prosthesis, each meniscal component being configured to cooperate with the tibial and femoral components in a different manner to allow alternative modes of operation of the knee prosthesis, wherein the tibial component comprises at least two pegs projecting upwardly from an upper surface of the tibial component and each meniscal component comprises at least one recess for receiving the pegs, the pegs being fixedly connected to or formed integrally with the tibial component.
12. A combination as claimed in claim 11, wherein the recess in one of the meniscal components is configured to allow gliding of the meniscal component across the upper surface of the tibial component in a substantially unrestrained manner.
13. A combination as claimed in claim 11 or 12, wherein at least one of the meniscal components is configured to cooperate with the tibial component such that relative movement therebetween is prevented.

14. A combination as claimed in any one of claims 11 to 13, wherein at least one meniscal component is configured to allow limited relative movement between the tibial and said meniscal components.
15. A combination as claimed in claim 14, wherein limited anterior-posterior and rotational movement is permitted between the said meniscal and tibial components.
16. A combination as claimed in claim 14 or 15, wherein limited medial-lateral movement is permitted between the said meniscal and tibial components.
17. A combination as claimed in any one of claims 11 to 16, wherein at least one of the pegs is locatable in at least one recess in a snap-fit manner.
18. A combination of a tibial component, a femoral component and a plurality of meniscal components substantially as hereinbefore described with reference to either of the embodiments illustrated in the accompanying drawings.



P.

<b>Patents Act 1977</b> <b>Examiner's report to the Comptroller under Section 17</b> <b>(The Search report)</b>	Application number GB 9516354.9
<b>Relevant Technical Fields</b>  (i) UK Cl (Ed.N)      A5R (RAJ, RAK) (ii) Int Cl (Ed.6)      A61F 2/38  <b>Databases (see below)</b> (i) UK Patent Office collections of GB, EP, WO and US patent specifications.  (ii) ONLINE: WPI	Search Examiner DR J HOULIHAN  Date of completion of Search 8 NOVEMBER 1995  Documents considered relevant following a search in respect of Claims :- 1-21

**Categories of documents**

<p><b>X:</b> Document indicating lack of novelty or of inventive step.</p> <p><b>Y:</b> Document indicating lack of inventive step if combined with one or more other documents of the same category.</p> <p><b>A:</b> Document indicating technological background and/or state of the art.</p>	<p><b>P:</b> Document published on or after the declared priority date but before the filing date of the present application.</p> <p><b>E:</b> Patent document published on or after, but with priority date earlier than, the filing date of the present application.</p> <p><b>&amp;:</b> Member of the same patent family; corresponding document.</p>
--	---

Category	Identity of document and relevant passages	Relevant to claim(s)
X,Y	GB 2252500 A (THACKRAY C F LTD) page 1 line 22 to page 2 line 6; page 2 lines 22-27; page 4 line 33 to page 5 line 3; page 6 lines 14-17; page 9 lines 21-24 and 29-33; page 10 lines 9-14	X: 1-5, 14-18 Y: 7 & 9
Y	EP 0186471 A2 (THACKRAY C F LTD) page 3 line 20 to page 4 line 3; page 8 line 34 to page 9 line 4; page 10 lines 25-27; Figures 6 and 7	7 & 9

**Databases:**The UK Patent Office database comprises classified collections of GB, EP, WO and US patent specifications as outlined periodically in the Official Journal (Patents). The on-line databases considered for search are also listed periodically in the Official Journal (Patents).